



CATALOGUE PAGES



Héra

Design Philippe STEPHANT

The HERA lamp with white porcelain lamp-shade is equipped with an 50 W – 12 V low pressure halogen bulb. The double arm, which is articulated at three points, can be rotated on its base. It is equipped with friction adjustment and integrated return spring. Arm amplitude : 0.95 m.

The lighting head moves in all the directions and can be inclined through 70°.

Dual intensity, 35 and 50 W.

Three-position switch located at the base of the arm.

Excellent distribution of the light beam onto the work surface.

Lighting head made of Polycarbonate. Arm made of steel wire. Articulations

in injected aluminium, base made of steel and ABS plastic. Cast iron weight

Main lead : 2.5 m. Double isolation, rated class 2, manufactured in compliance with European standards.

For more information on this product download the technical sheet on www.manade.com

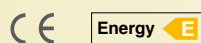

50 W
GY 6,35

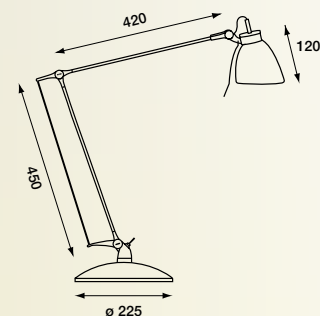

References

- HERA chromed : **HÉRA 08**
- HERA aluminium : **HÉRA 29**



08 Chrome



29 Silver

